



U.S. Department  
of Transportation  
**Federal Highway  
Administration**

400 Seventh St., S.W.  
Washington, D.C. 20590

February 8, 2002

Refer to: HSA-10/WZ-108

Mr. Dave Gertz  
TraFFix Devices, Inc.  
220 Calle Pintoresco  
San Clemente, CA 92672

Dear Mr. Gertz:

Thank you for your letter of January 9, 2002, requesting Federal Highway Administration (FHWA) acceptance of your company's portable sign stands and barricades as crashworthy traffic control devices for use in work zones on the National Highway System (NHS). Accompanying your letter was a report of the crash testing conducted by Karco Engineering and a video of the tests. You also asked for our review of the results of tests 1, 2, 3, and 5 that accompanied your July 9, 2001, letter (as you requested at the time we limited our review to the Little Buster stand, the subject of test 4.) You requested that we find these devices acceptable for use on the NHS under the provisions of National Cooperative Highway Research Program (NCHRP) Report 350 "Recommended Procedures for the Safety Performance Evaluation of Highway Features."

#### **Introduction**

The FHWA guidance on crash testing of work zone traffic control devices is contained in two memoranda. The first, dated July 25, 1997, titled "INFORMATION: Identifying Acceptable Highway Safety Features," established four categories of work zone devices: Category I devices were those lightweight devices which could be self-certified by the vendor, Category II devices were other lightweight devices which needed individual crash testing, Category III devices were barriers and other fixed or massive devices also needing crash testing, and Category IV devices were trailer mounted lighted signs, arrow panels, etc. The second guidance memorandum was issued on August 28, 1998, and is titled "INFORMATION: Crash Tested Work Zone Traffic Control Devices." This later memorandum lists devices that are acceptable under Categories I, II, and III.

A brief description of the devices in the two letters follows:

July 9, 2001

**Test 1. Sign Stand. Rubber Pole Base with 30 pound ballast, 36 x 36 inch aluminum sign, and light.** The vertical mast of this stand was 2 x 2 inch square 16 gage steel tubing, 66 inches long. The aluminum signs were supported 18 inches above the ground.

Component	Material	Height to top	Width	Thickness	Weight
Base	Rubber	n/a	16 x 18 in	2 inches	30 pounds
Mast	Steel	66 in long	2 inches	16 gage	9 pounds
Sign	0.080 Al	69 inches	36 x 36 in	0.080 in	9 pounds
Light	Empco Light	78 inches	n/a	n/a	4.5 pounds

**Test 2. Big Buster Sign Stand with 48 x 48 inch aluminum sign.** The vertical mast of this stand is telescoping square aluminum tubes. The aluminum sign is mounted 66 inches above the ground.

Component	Material	Height to top	Width	Thickness	Weight
Legs	Aluminum	n/a	1.25 in	0.100 in	3 pounds ea.
Outer Mast	Aluminum	n/a	1.50 in	0.100 in	3 pounds
Inner Mast	Aluminum	n/a	1.25 in	0.100 in	3 pounds
Sign	Aluminum	133 inches	48 x 48 in	0.080	16 pounds
Light	none	n/a	n/a	n/a	n/a

**Test 3. Aluminum Buster Sign Stand with 48 x 48 inch aluminum sign bolted to inner mast and Plastic Flag Holder.** The vertical mast of this stand is 1.50 inch square aluminum with 0.100 wall, and 1.25 inch square PVC tubing with 0.250 inch wall. The 0.080 inch thick aluminum sign weighed 16 pounds and was mounted at a height of 18 inches above the ground.

Component	Material	Height to top	Width	Thickness	Weight
Legs	Aluminum	n/a	1.25 in	0.100 in	2 pounds ea
Outer Mast	Aluminum	n/a	1.50 in	0.100 in	3 pounds
Inner Mast	PV	n/a	1.25 in	0.25 in	5 pounds
Sign	Aluminum	86 inches	48 x 48 in	0.080 in	16 pounds
Light	[flag bracket]	n/a	n/a	n/a	n/a

**Test 4. Little Buster Sign Stand with 1220 x 1220 mm (48 x 48 inch) Aluminum Sign bolted to Full Length Inner Mast and Traffix Flag holder.** Sign mounted 460 mm (18 inches) above ground. This device was accepted in FHWA Acceptance Letter WZ-81.

**Test 5. Rubber Base Sign Stand with Pinned Inner Mast, 48 x 48 inch aluminum sign and B-Light.** The vertical mast of this stand was 1.75 x 1.75 inch square 16 gage steel tubing, 72 inches long. The 0.080 inch aluminum signs weighed 16 pounds and was supported 12 inches above the ground. The Type B warning light weighed 4.5 pounds and was attached to the top of the mast using an Emco plastic flag bracket.

Component	Material	Height to top	Width	Thickness	Weight
Base	Rubber	n/a	17 x 27 in	2 in	40 pounds
Mast	Steel	72 in	1.75 x 1.75 in	16 gage	9 pounds
Sign	Aluminum	80 in	48 x 48	0.080 in	16 pounds
Light	Type B	n/a	n/a	n/a	n/a

January 9, 2002

**Test 1. Little Buster Sign Stand with 48 x 48 inch aluminum sign with Slip-over Tube Mast.** The vertical mast outside sleeve of this stand was 1.5 inch square steel 12 gage tube. The 0.080 inch thick aluminum sign weighed 16 pounds and was mounted at a height of 18 inches above the ground.

Component	Material	Height to top	Width	Thickness	Weight
Base	Steel	16 inches	2.5 inches	0.250 wall	30 pounds
Mast	Steel	86 inches	1.2 inches	16 ga	7 pounds
Sign	Aluminum	85 inches	48 x 48 in	0.080	16 pounds
Light	[flag bracket]	n/a	n/a	n/a	n/a

**Test 2. Type 3 Plastic Barricade with Plastic Posts and Pinned Rubber Bases, carrying a 48 x 48 inch diamond sign.** The vertical posts are extruded PVC plastic, as crash tested by Davidson Plastics and found acceptable in our letter WZ-39. The extruded plastic rails are High Density Polyethelene, also tested previously. They were attached to the vertical posts using grade two 1/4 inch bolts. This barricade carried a lightweight corrugated plastic diamond sign mounted 12 inches above the pavement. It was attached to the rails with grade two 1/4 inch bolts.

Component	Material	Height to top	Width	Thickness	Weight
Base	Rubber	n/a	17 x 27 in	2 in	40 pounds
Vertical posts	X section Plastic	72 in	1.75 in	1.75 in	
Horiz. Panels	Extruded Plastic	60 in	8 ft x 8 in	3/4 in	6 pound ea
Sign	Corrug. Plastic	80 in	48 x 48 in	0.4 inch	4.5 pounds

**Test 3. Econo Buster Sign Stand with 48 x 48 inch aluminum sign with Slip-over Outer Tube Mast.** The vertical mast outside sleeve of this stand was 1.5 inch square steel 12 gage tube. The 0.080 inch thick aluminum sign weighed 16 pounds and was mounted at a height of 16 inches above the ground.

Component	Material	Height to top	Width	Thickness	Weight
Base	Steel	13 inches	1.0 inch	1/8 inch	19 pounds
Mast	Steel	84 in	1.2 x 1.2 in	16 gage	7 pounds
Sign	Aluminum	84 in	48 x 48	0.080	16 pounds
Light	[flag bracket]	n/a	n/a	n/a	n/a

**Test 4. Type III Plastic panel Barricade with Steel Post uprights and Lights,** tested with 48 x 48 inch aluminum sign. The vertical uprights were 1.75 inch square 16 gage steel posts, 72 inches long. The panels were 96 inches long by 8.5 inches wide and 3/4 inch thick corrugated plastic. The lights were Empco lights weighing 4.5 pounds mounted on the vertical uprights.

Component	Material	Height to top	Width	Thickness	Weight
Base	Rubber	n/a	17 x 27 in	2 in	40 pounds
Vertical posts	Steel	72 in	1.75 x 1.75 in	16 gage	9 pounds
Horiz. Panels	Corrug. Plastic	72 in	8 ft x 8 in	3/4 in	6 pound ea
Light	[Empco Light]	90 inches	n/a	n/a	4.5 pounds

### Testing

Full-scale automobile testing was conducted on your company's devices. Two stand-alone examples of the device were tested in tandem, one head-on and the next placed six meters downstream turned at 90 degrees, as called for in our guidance memoranda. The complete device as tested is shown in Enclosure 1. The crash testing is summarized in the table below:

Test # (6/9/2001 letter)	Test 1	Test 2	Test 3	Test 5
Test Article	Sign Stand	Big Buster	Al. Buster	Rubber Base
Vehicle Inertial Mass	809 kg	904 kg	904 kg	885 kg
Impact Speed, Head-on	101.43 km/h	100.42 km/h	100.40 km/h	101.33 km/h
Impact Speed, 90 Dcg.	99.81 km/h	99.05 km/h	99.80 km/h	97.49 km/h
Velocity Change	0.45 m/s	0.38 m/s	0.0.2 m/s	1.04 km/h
Vehicle crush	Moderate	None	Minor	Moderate
Occupant Compart. Intrusion	None	None	None	None
Windshield Damage	Major	Moderate	None	None
Overall Assessment	Marginal	Pass	Pass	Pass

Windshield damage in Test 1 was primarily due to the flat impact of the warning light. A small but dense area of cracking was surrounded by more moderated spider web cracking. A driver should be able to see around the opaque area.

Windshield damage in Test 2 was due to the impact of the sign's mast contacting the roof line. Moderate cracking radiated from this impact point.

Test # (1-9-02 letter)	Test 1	Test 2	Test 3	Test 4
Test Article	Little Buster Sign Stand	Type III Plastic Leg Barricade	Econo Buster Sign Stand	Type III Steel Leg Barricade
Vehicle Mass	873 kg	886 kg	873 kg	886 kg
Impact Speed Head-on	99.52 km/h	98.76 km/h	100.0 km/hr	99.92 km/hr
Impact Speed 90 Deg.	97.92 km/h	97.39 km/h	97.84 km/h	97.47 km/hr
Velocity Change	0.44 m/s	0.38 m/s	0.60 m/s	0.68 m/s
Vehicle crush	Minor	Minor	Minor	Minor
Occupant Compart. Intrusion	None	None	None	None
Windshield Damage	Broken, shattered	Broken, shattered	Broken, shattered	Broken, shattered
Overall Assessment	Marginal	Marginal	Marginal	Marginal

Windshield damage in Tests 1 and 3 resulted from the flat impact of the aluminum sign panel in the head-on test. Cracking was distributed over the whole windshields of both cars but did not significantly impair the driver's ability to see. Deflection of the glass was between two and three inches. Therefore, this device will be considered marginally acceptable.

Test 2 was of a plastic framed Type III barricade. The vertical supports of this barricade shattered upon impact, allowing the horizontal rails to strike the windshield in both the head on and 90 degree tests. Although there was no windshield penetration in this case, the potential for rigid horizontal panels to spear the vehicle is higher. It is critical, therefore, that this design use flexible, lightweight horizontal rails as tested. The corrugated plastic sign panel mounted on the barricade is acceptable for use as tested.

Windshield damage in Test 4 also resulted from the flat impact of the sign panel mounted to the barricade. The light gage steel vertical supports crumpled upon impact. The performance of these vertical supports was better than the plastic supports in Test 2, but did not hold the barricade together as well as the hot-rolled, high carbon steel angles, nor the perforated square steel tubes used in the generic Type III barricade designs distributed by the FHWA in our letter WZ-85. Even though the results of this test were acceptable, FHWA discourages the use of rigid aluminum or plywood sign panels centered on Type III barricades. We prefer that lightweight plastic sign substrates be used in this location, such as the sign in Test 2.

### Findings

Damage to the windshields of the test vehicles varied as discussed above. Our assessment of the tested devices is summarized here.

July 9, 2001

**Test 1. Sign Stand. Rubber Pole Base with 30 pound ballast, 36 x 36 inch aluminum sign, and light.** Acceptable, but marginal

**Test 2. Big Buster Sign Stand with 48 x 48 inch aluminum sign.** Acceptable

**Test 3. Aluminum Buster Sign Stand with 48 x 48 inch aluminum sign bolted to inner mast and Plastic Flag Holder.** Acceptable

**Test 4. Little Buster Sign Stand with 1220 x 1220 mm (48 x 48 inch) Aluminum Sign bolted to Full Length Inner Mast and Traffix Flag holder. Sign mounted 460 mm (18 inches) above ground.** Acceptable

**Test 5. Rubber Base Sign Stand with Pinned Inner Mast, 48 x 48 inch aluminum sign and B-Light.** Acceptable

January 9, 2001

**Test 1. Little Buster Sign Stand with 48 x 48 inch aluminum sign with Slip-over Tube Mast.** Acceptable, but marginal

**Test 2. Type III Plastic Barricade with Plastic Posts and Pinned Rubber Bases, carrying a 48 x 48 inch diamond sign.** Acceptable, but marginal

**Test 3. Econo Buster Sign Stand with 48 x 48 inch aluminum sign with Slip-over Outer Tube Mast.** Acceptable, but marginal

**Tube 4. Type III Plastic panel Barricade with Steel Post uprights and Lights, tested with 48 x 48 inch aluminum sign.** Acceptable with lightweight plastic sign panel

The results of the testing are compared to the FHWA requirements above. The devices described above and shown in the enclosed drawings for reference are acceptable as noted for use on the NHTS under the range of conditions tested, when proposed by a State.

- Our acceptance is limited to the crashworthiness characteristics of the devices and does not cover their structural features, nor conformity with the Manual on Uniform Traffic Control Devices.
- Any changes that may adversely influence the crashworthiness of the device will require a new acceptance letter.
- Should the FHWA discover that the qualification testing was flawed, that in-service performance reveals unacceptable safety problems, or that the device being marketed is significantly different from the version that was crash tested, it reserves the right to modify or revoke its acceptance.
- You will be expected to supply potential users with sufficient information on design and installation requirements to ensure proper performance.
- You will be expected to certify to potential users that the hardware furnished has essentially the same chemistry, mechanical properties, and geometry as that submitted for acceptance, and that they will meet the crashworthiness requirements of FHWA and NCHRP Report 350.
- To prevent misunderstanding by others, this letter of acceptance, designated as number WZ-108 shall not be reproduced except in full. This letter, and the test documentation upon which this letter is based, is public information. All such letters and documentation may be reviewed at our office upon request.
- They may include patented components and if so are considered "proprietary." The use of proprietary work zone traffic control devices in Federal-aid projects is generally of a temporary nature. They are selected by the contractor for use as needed and removed upon completion of the project. Under such conditions they can be presumed to meet requirement "a" given below for the use of proprietary products on Federal-aid projects. On the other hand, if proprietary devices are specified for use on Federal-aid projects, except exempt, non-NHTS projects, they: (a) must be supplied through competitive bidding with equally suitable unpatented items; (b) the highway agency must certify that they are essential for synchronization with existing highway facilities or that no equally suitable alternative exists or; (c) they must be used for research or for a distinctive type of construction on relatively short sections of road for experimental purposes. Our regulations concerning proprietary products are contained in Title 23, Code of Federal Regulations, Section 635.411, a copy of which is enclosed.

Sincerely yours,

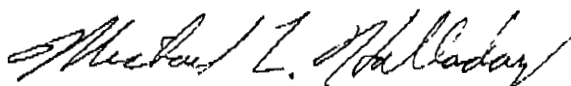

Michael L. Halladay  
Acting Program Manager, Safety

Enclosure

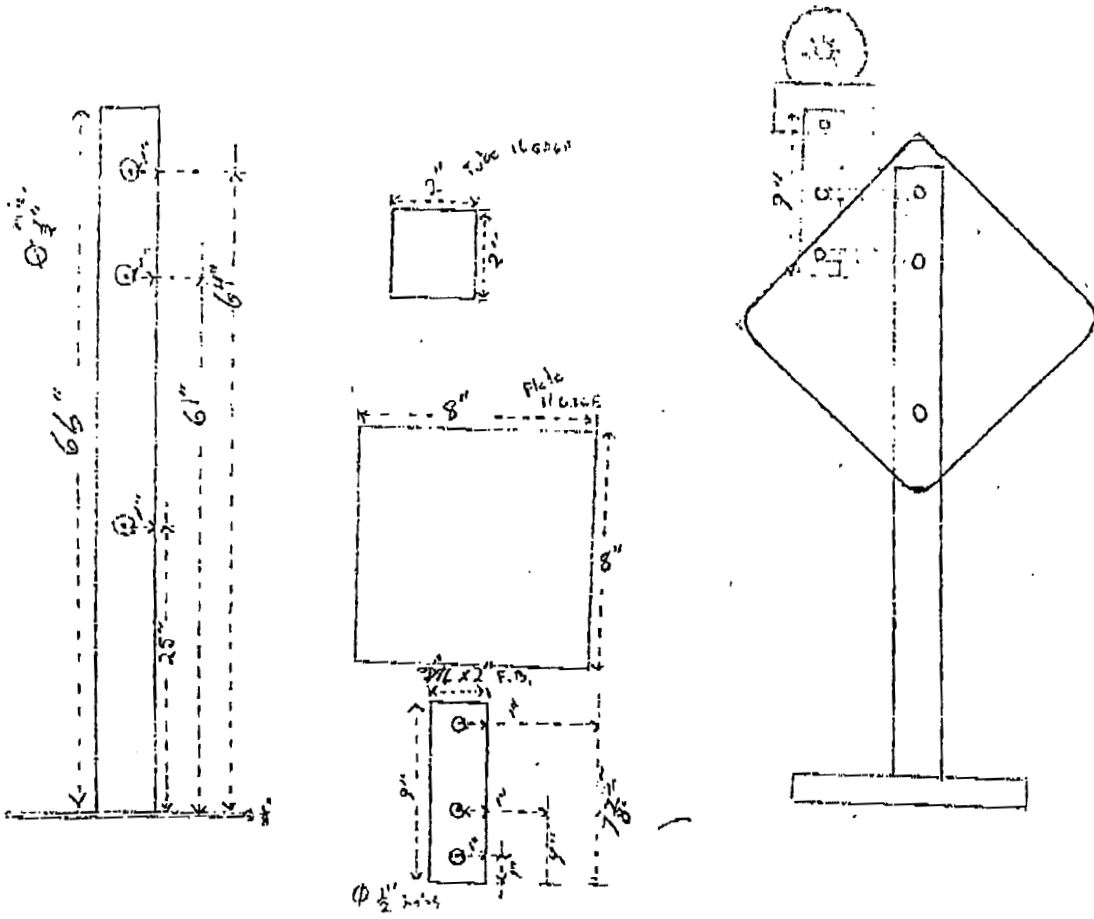

Figure 1. - Rubber Pole Base with 40 lb. Ballast, Thirty-six Inch by Thirty-six Inch Aluminum Sign, and Light.



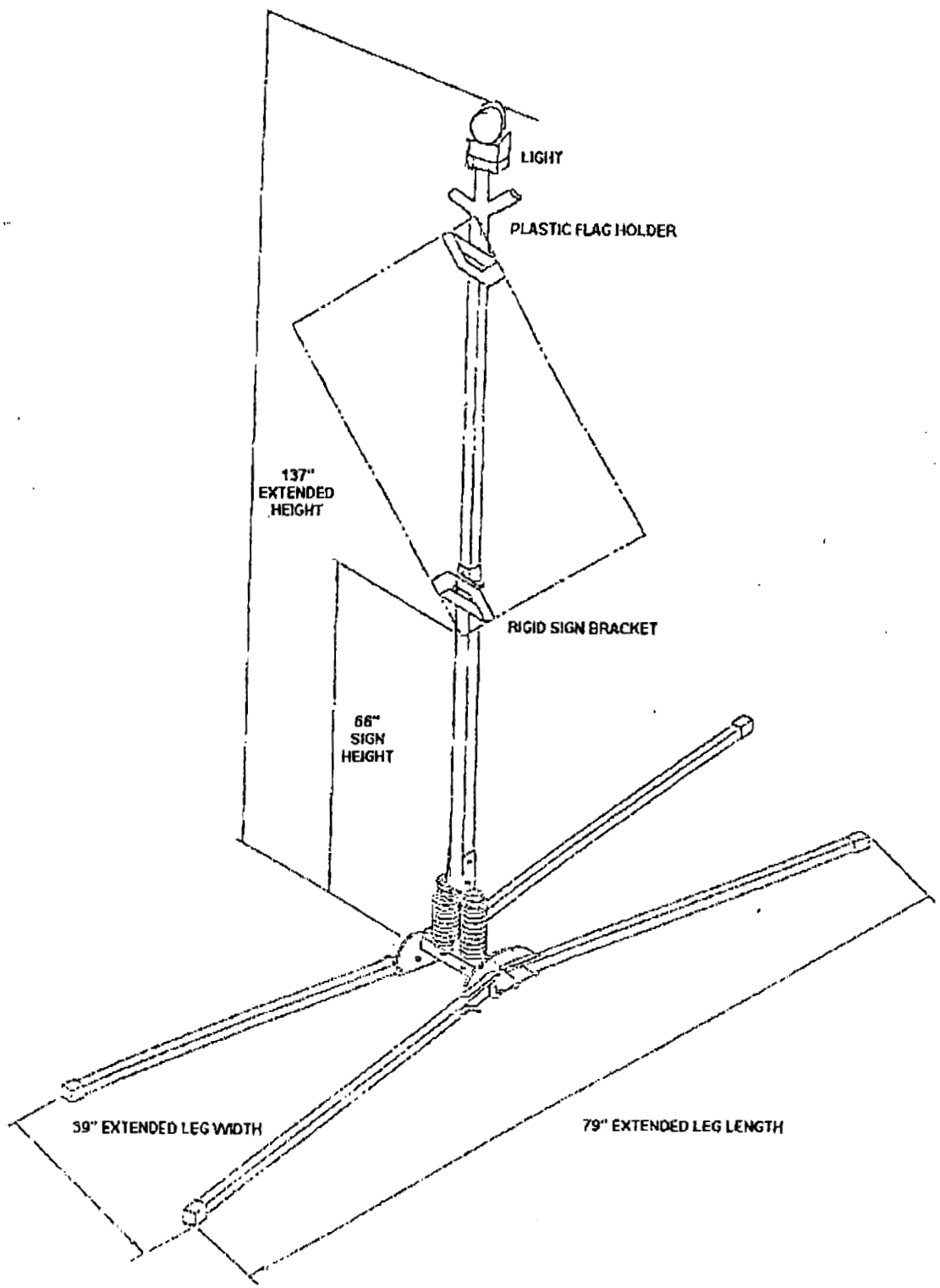

Figure 2. – Big Buster Sign Stand with Forty-eight Inch by Forty Eight Inch Aluminum Sign, Aluminum Inner Mast, and Plastic Flag Holder; Sign Height Sixty-six Inches Above Ground.

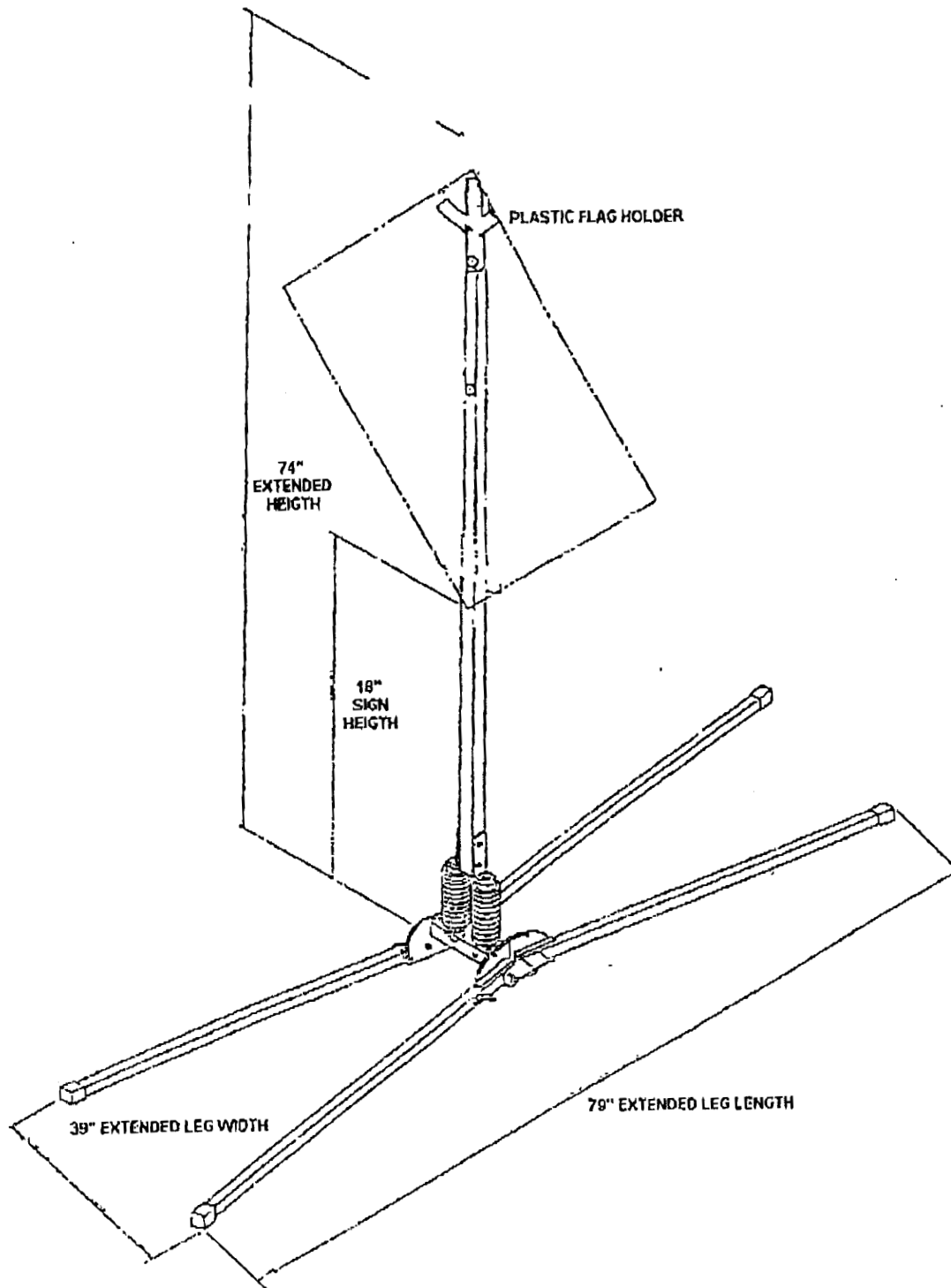

Figure 3. – Aluminum Buster Sign Stand with Forty-eight Inch by Forty-eight Inch Aluminum Sign Bolted to Inner Mast and Plastic Flag Holder; Sign Height Eighteen Inches Above Ground.

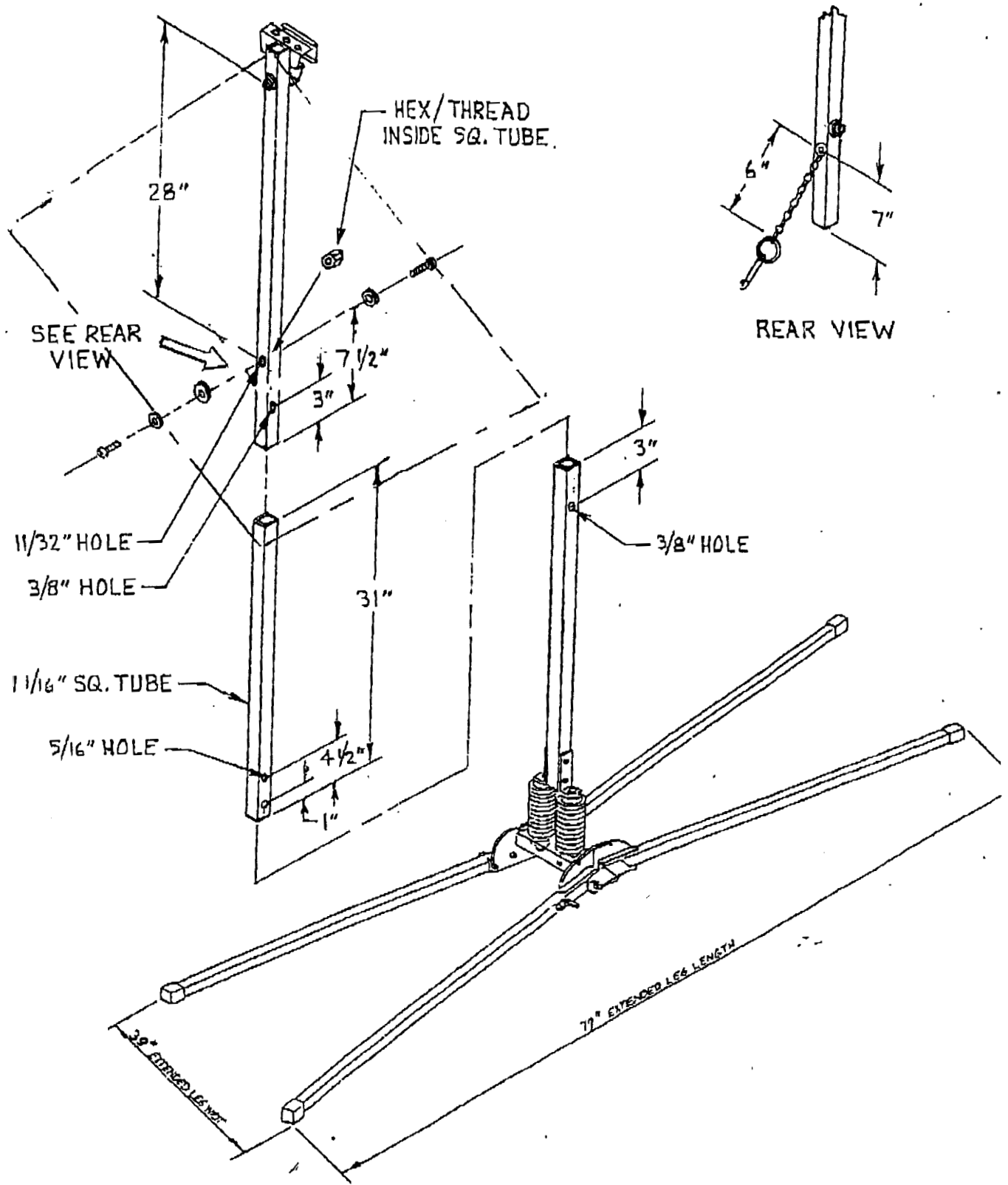

Figure 4. – Little Buster Sign Stand with Full Length Inner Mast and TrafFix Flag Holder; Sign Height Eighteen Inches Above Ground.

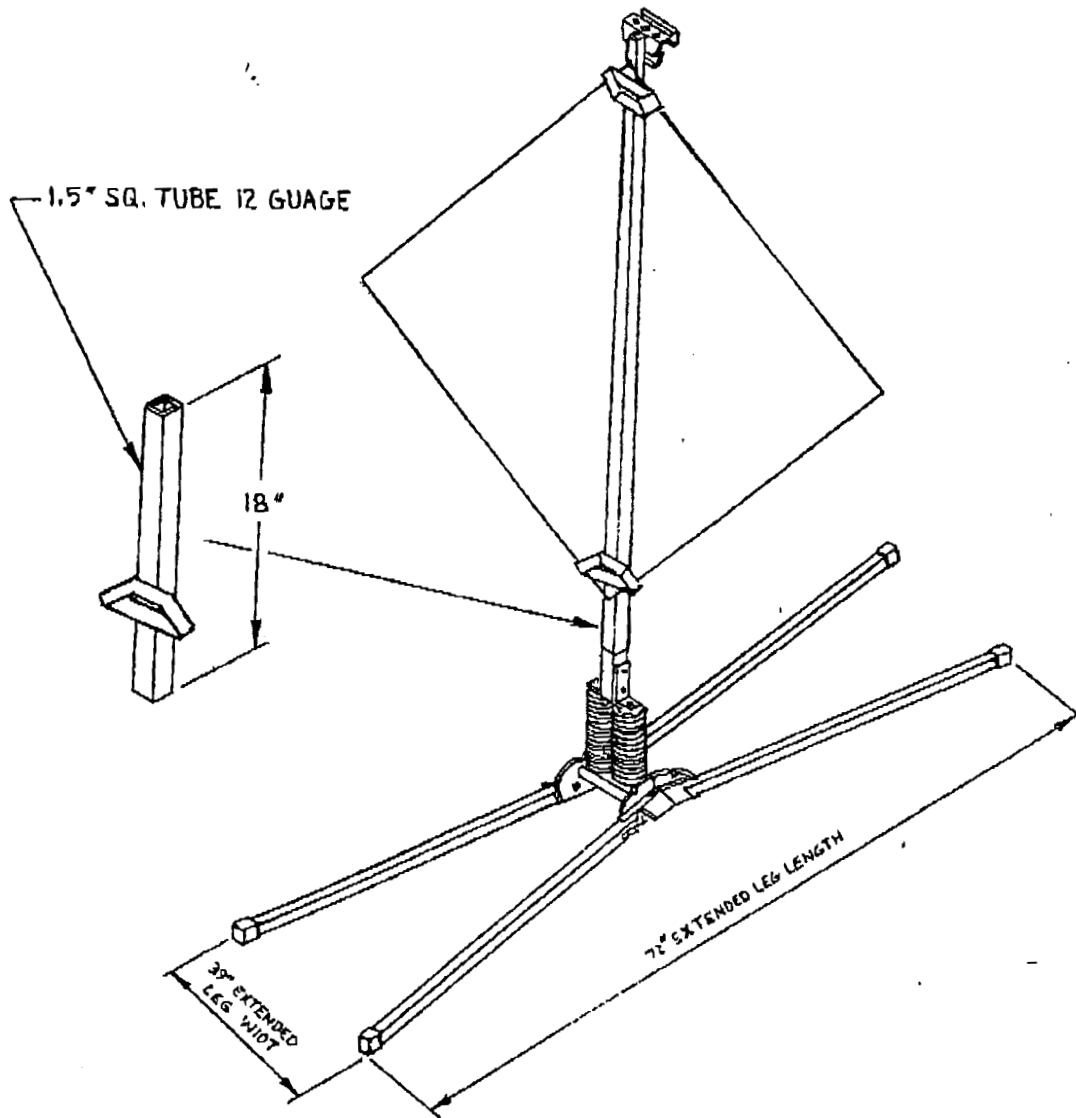

Figure 1. – Little Buster Sign Stand with Forty-eight Inch by Forty-eight Inch Aluminum Sign with Slip-over Tube Mast; Sign Height Eighteen Inches Above Ground.

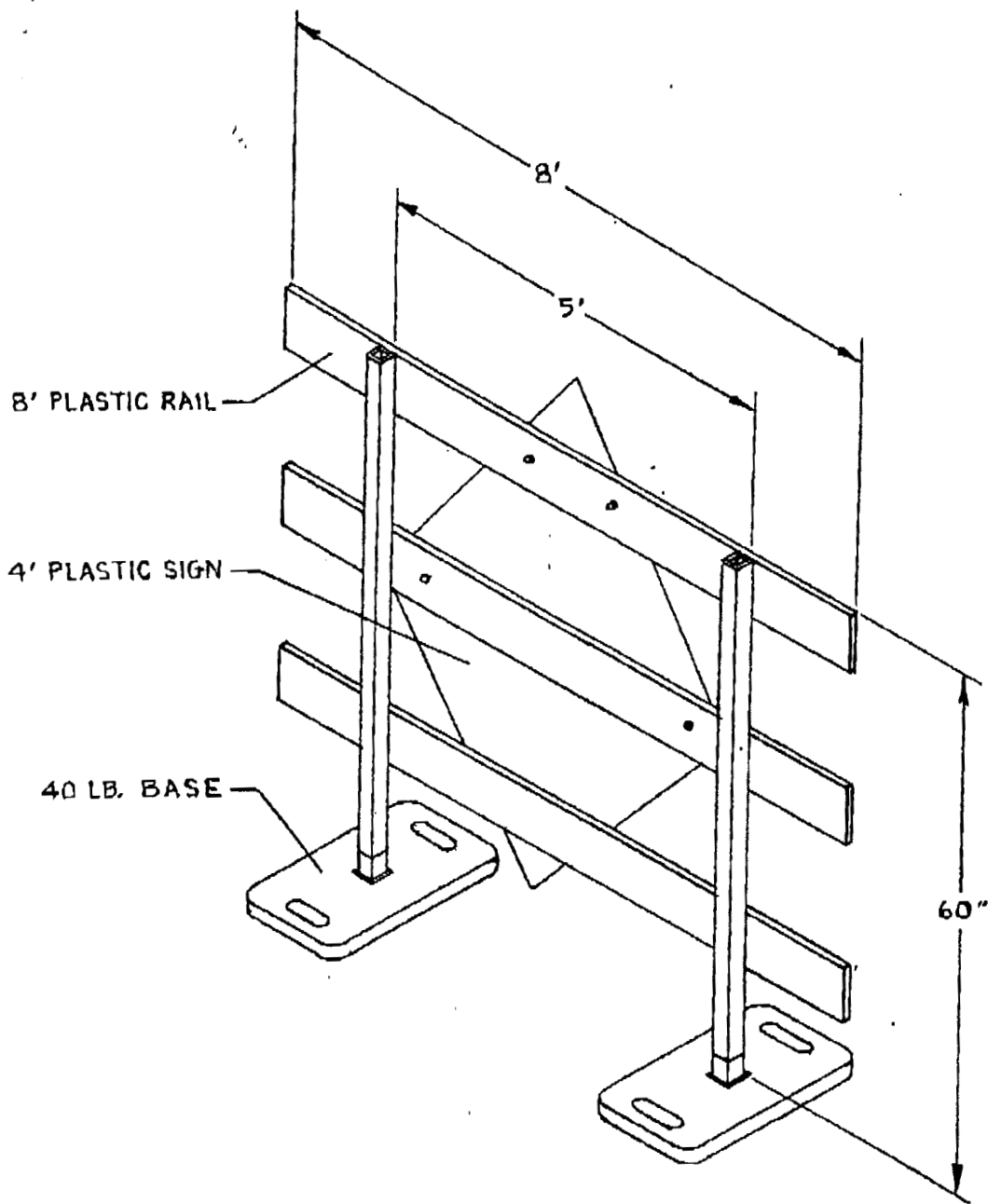

Figure 2. - Type 3 Plastic Barricade with Plastic Posts and Pinned Rubber Bases, Forty-eight Inch by Forty-eight Inch Corrugated Plastic Sign; Sign Height Twelve Inches Above Ground.

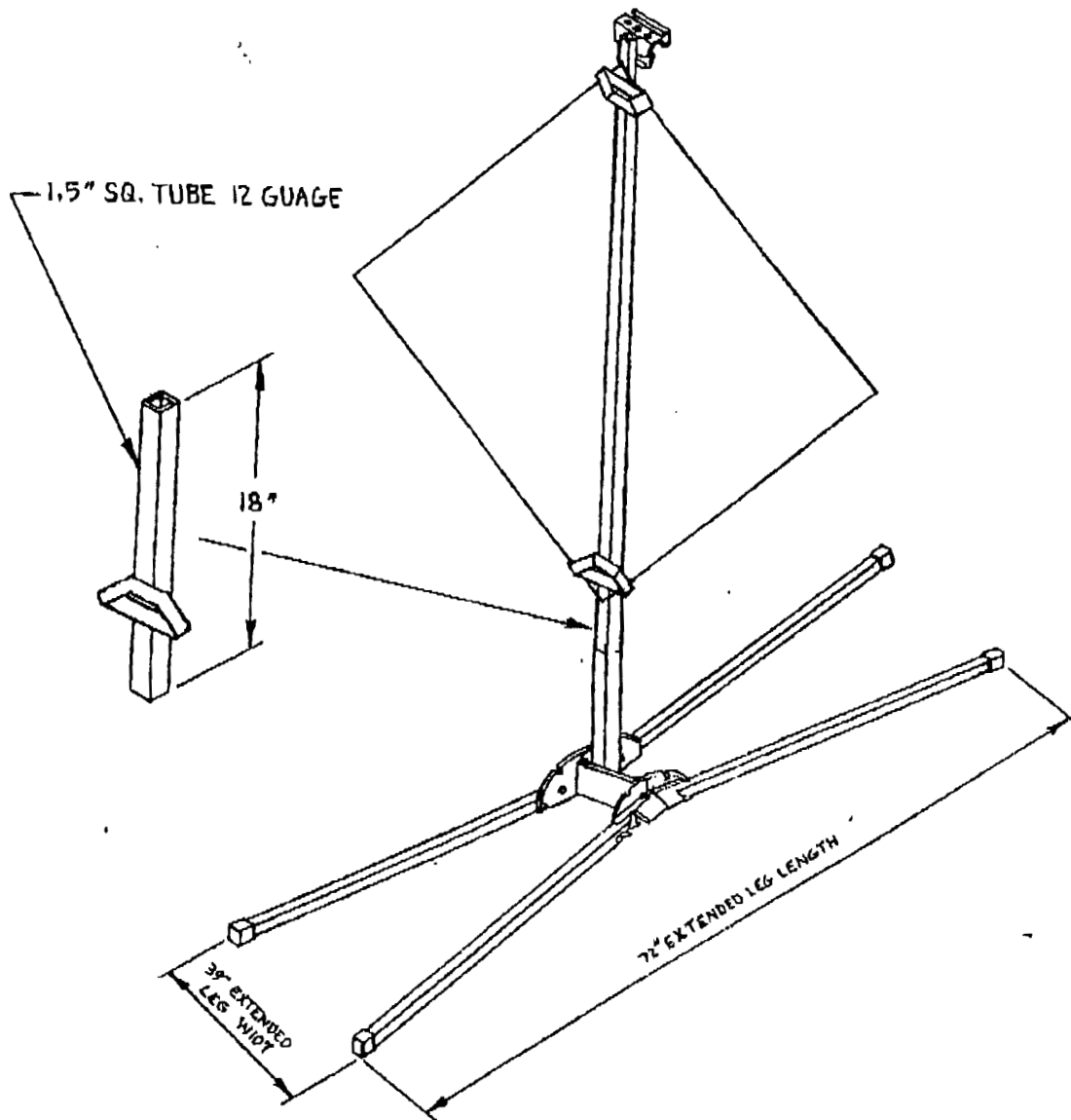

Figure 3. – Econo Buster Sign Stand with Forty-eight Inch by Forty-eight Inch Aluminum Sign with Slip-over Outer Tube Mast; Sign Height Sixteen Inches Above Ground.

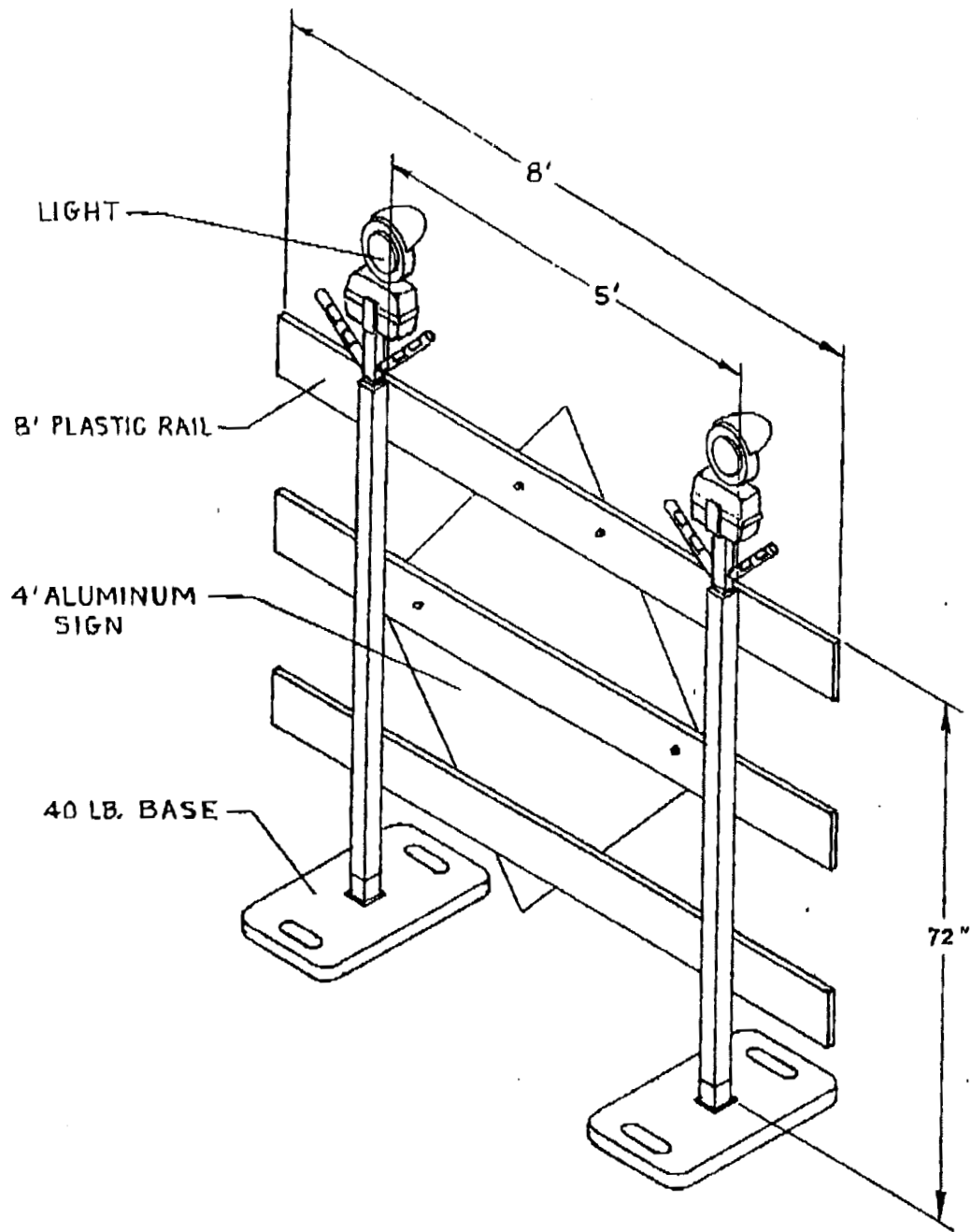

Figure 4. — Type 3 Plastic Barricade with Steel Post Uprights with Lights, Forty-eight Inch by Forty-eight Inch Aluminum Sign; Sign Height Twelve Inches Above Ground.

§ 635.417 Convict produced mater  
 (a) Materials produced after Jt  
 1991, by convict labor may only t  
 incorporated in a Federal-aid hig  
 construction project if such mat  
 have been.

(1) Produced by convicts who al  
 parole, supervised release, or probe



pipes, and (2) the number and types of  
 such alternatives which must be set  
 forth in the specifications for various  
 types of drainage installations.

(e) Reference in specifications and on  
 plans to single trade name materials  
 will not be approved on Federal-aid  
 contracts.

§ 635.413 Warranty clauses.

The SHA may include warranty pro-  
 visions in National Highway System  
 (NHS) construction contracts in ac-  
 cordance with the following:

(a) Warranty provisions shall be for a  
 specific construction product or fea-  
 ture. Items of maintenance not eligible  
 for Federal participation shall not be  
 covered.

(b) All warranty requirements and  
 subsequent revisions shall be sub-  
 mitted to the Division Administrator  
 for advance approval.

(c) No warranty requirement shall be  
 approved which, in the judgment of the  
 Division Administrator, may place an  
 undue obligation on the contractor for  
 items over which the contractor has no  
 control.

(d) A SHA may follow its own proce-  
 dures regarding the inclusion of war-  
 ranty provisions in non-NHS Federal-  
 aid contracts.

[50 FR 41274, Aug. 25, 1985]

forth in the plans and specifications for  
 a project, unless:

(1) Such patented or proprietary item  
 is purchased or obtained through com-  
 petitive bidding with equally suitable  
 unpatented items; or

(2) The State highway agency cer-  
 tifies either that such patented or pro-  
 prietary item is essential for synchro-  
 nization with existing highway facil-  
 ities, or that no equally suitable alter-  
 native exists; or

(3) Such patented or proprietary item  
 is used for research or for a distinctive  
 type of construction on relatively  
 short sections of road for experimental  
 purposes.

(b) When there is available for pur-  
 chase more than one nonpatented, non-  
 proprietary material, semifinished or  
 finished article or product that will  
 fulfill the requirements for an item of  
 work of a project and these available  
 materials or products are judged to be  
 of satisfactory quality and equally ac-  
 ceptable on the basis of engineering  
 analysis and the anticipated prices for  
 the related item(s) of work are esti-  
 mated to be approximately the same,  
 the PS&E for the project shall either  
 contain or include by reference the  
 specifications for each such material or  
 product that is considered acceptable  
 for incorporation in the work. If the  
 State highway agency wishes to sub-  
 stitute some other acceptable material  
 or product for the material or product  
 designated by the successful bidder or  
 bid as the lowest alternate, and such  
 substitution results in an increase in  
 costs, there will not be Federal-aid par-  
 ticipation in any increase in costs.

(c) A State highway agency may re-  
 quire a specific material or product  
 when there are other acceptable mate-  
 rials and products, when such specific  
 choice is approved by the Division Ad-  
 ministrator as being in the public in-  
 terest. When the Division Administra-  
 tor's approval is not obtained, the item  
 will be nonparticipating unless bidding  
 procedures are used that establish the  
 unit price of each acceptable alter-  
 native. In this case Federal-aid partici-  
 pation will be based on the lowest price  
 so established.

(d) Appendix A sets forth the FHWA  
 requirements regarding (1) the speci-  
 fication of alternative types of culvert

mitted sufficiently in advance of the  
 need for the waiver in order to allow  
 time for proper review and action on  
 the request. The FHWA will have ap-  
 proval authority on the request.

(3) Requests for waivers may be made  
 for specific projects, or for certain ma-  
 terials or products in specific geo-  
 graphic areas, or for combinations of  
 both, depending on the circumstances.

(4) The denial of the request by the  
 FHWA may be appealed by the State  
 to the Federal Highway Administrator  
 (Administrator), whose action on the  
 request shall be considered adminis-  
 tratively final.

(5) A request for a waiver which in-  
 volves nationwide public interest or  
 availability issues or more than one  
 FHWA region may be submitted by the  
 FHWA to the Administrator for ac-  
 tion.

(6) A request for waiver and an appeal  
 from a denial of a request must include  
 facts and justification to support the  
 granting of the waiver. The FHWA re-  
 sponse to a request or appeal will be in  
 writing and made available to the pub-  
 lic upon request. Any request for a na-  
 tionwide waiver and FHWA's action on  
 such a request may be published in the  
 FEDERAL REGISTER for public comment.  
 (7) In determining whether the waiver  
 described in paragraph (c)(1) of this  
 section will be granted, the FHWA will  
 consider all appropriate factors includ-  
 ing, but not limited to, cost, adminis-  
 trative burden, and delay that would be  
 imposed if the provision were not  
 waived.

(c) Standard State and Federal-aid  
 contract procedures may be used to as-  
 sure compliance with the requirements  
 of this section.

[48 FR 59104, Nov. 25, 1983, as amended at 49  
 FR 14821, May 3, 1984; 58 FR 38975, July 21,  
 1993]

EDITORIAL NOTE: For a waiver document  
 affecting § 635.410, see 60 FR 15478, Mar. 24,  
 1995.

§ 635.411 Material or product selec-  
 tion.

(a) Federal funds shall not partici-  
 pate, directly or indirectly, in payment  
 for any premium or royalty on any pat-  
 ented or proprietary material, speci-  
 fication, or process specifically set

APPENDIX A TO SUBPART D OF P,  
 635—SUMMARY OF ACCEPTABLE C  
 TERMS FOR SPECIFYING TYPES  
 CULVERT PIPES

[50 FR 1923, Jan. 25, 1985, as amended a  
 FR 38975, July 21, 1993]

APPENDIX A TO SUBPART D OF P,  
 635—SUMMARY OF ACCEPTABLE C  
 TERMS FOR SPECIFYING TYPES  
 CULVERT PIPES

Type of drainage installation	Alternatives required		ASHTO des- criptions to be in- cluded with alter- natives	Application	Remarks
	Yes	No			
Cross drains under high- type pavement <sup>1</sup>	X		M-170 and M- 190	Statewide	Any AASHTO-ap- proved materia Do. <sup>2</sup>
Other cross-drain installa- tions	X		M-36	do	Do. <sup>2</sup>
Side-drain installations	X			Individual installa- tion	Specified to meet special condi- tions
Special installation condi- tions		X		do	Specified to meet special condi- tions

<sup>1</sup> High-type pavement is generally described as FHWA construction type codes I, J, K, L, and plant mix and penetration ma-  
 adum segments, respectively shown in the right-hand column, or type codes G and H having a combined thickness of surface  
 and base of 7 in or more (or equivalent) or that are constructed on rigid bases.  
<sup>2</sup> Types not included in currently approved AASHTO specifications may be specified if recommended by the State with ad-  
 equate justification and approved by FHWA.

Subpart E—Interstate  
 Maintenance Guidelines

§ 635.501 Purpose.

To prescribe Interstate maintenance  
 guidelines and establish the policy and  
 procedures to insure that the condition  
 of Interstate routes is maintained at

SOURCE: 45 FR 29793, Mar. 31, 1980, unless  
 otherwise noted.